



DP-504/DP-508 Stepper Driver

User's Manual

	Content
--	---------

1. Summary	1
1-1. Characteristic	1
1-2. Application	1
1-3. Electric characters	1
2. Operation Guidance	2
2-1. Safety	2
2-2. Attention	2
2-3. Installation	2
3. Common Terminals	3
3-1. Control signal terminals	3
3-1-1. Description of Control signals terminals	3
3-1-2. Sequential chart of control signal	4
3-1-3. Input circuit	4
3-2. Power Terminals	5
3-2-1. Description of Heavy-current terminal	5
3-2-2. Requirement of power supply	5
3-2-3. Wiring	5
3-3. Function Setting	6
3-3-1. Current Setting	6
3-3-2. Subdivision Setting	7
3-4. Function for Protection	7
4. Dimension installation and wiring	8
4-1. Dimension	8
4-2. Installation	8
4-3. Typical Wiring	9
5. Malfunction Diagnoses and Solution	10
6. Motor Selection	11

1. Summary

DP-504/DP-508 subdivision stepper driver with 40VDC/80VDC input, 5.0A output is used for all the two- phase hybrid stepper motor whose rated current is below 5.0 A. Based on the pure sine wave current control technology, this series product have a good performance in smoothly running with low noise, meets the high resolution requirement of the numerical control equipments, such as laser marking machine, CNC machine etc.

1-1. Characteristic

- Low noise on motor running.
- Power supply reaches 40VDC/80VDC.
- Effective value of output current can up to 5.0A.
- Dynamic selection on subdivision with maximal value of 200.
- Matched all the 4/6/8 leads motor whose current is below 5.0 A.
- Photo isolator input signal.
- Easy-operation on current setting and selection by user.
- Over-voltage and over-current protection.

1-2. Application

This series product can well meet the requirement of the small and medium automation devices and instruments, such as aerodynamic marking machine, labeling machine, cutting machine, laser marking machine, plotter, small carving machine, CNC machine etc., especially having a perfect performance on the devices which require low noise and vibration, high precision and speed.

1-3. Electric characters

Item		Min. value	Typical value	Max. value
Power supply (VDC)	DP-504	20	36	40
	DP-508	20	80	80
Effective value of output current		0	-	5
Logic input current (mA)		4	7	16
Stepper pulse frequency (KHz)		0	-	200
Insulation resistance(MΩ)		500	-	-
Ambient temperature		0°C~50°C		
Max working temperature		70°C		
Humidity		40%~90% RH (no condensation)		
Vibration		5.9m/s ² Max		
Storage temperature		-20°C~65°C		
Dimension		138mm×85mm×38mm		

2. Operation Guidance

Please read the following suggestion carefully before you install the driver.

2-1. Safety

- The driver is authorized to be installed and operated by the professionals and technicians.
- Don't turn on the power before you connect the motor.
- Make sure that the driver input meets the technical requirements.
- Don't make the setting or measure operations on the motor and driver during power on.
- Please do the wiring, installation and parameter setting after power is off for more than 3 minutes.
- Ensure the connection operation is absolutely correct and fixable before you turn on the power, including the power wire, motor cable and signal cable.
- Avoid electromagnetic interference.

2-2. Attention

- Please use shield cable for signal input, and leave each other for distance. The further the distance, the better the interference is avoided.
- Please connect the motor cover to the GND terminal.
- Don't operate on the output terminal when power on, or else the driver will be damaged.

2-3. Installation

- Don't install the driver next to the heat producing appliance.
- Don't exposure the driver to the dusty, corrosive gas, elevated humidities, and advised to use with small vibration.
- For perfect conducting, please ensure the fixation between earth wire of host computer, driver, motor and ground.

3. Common Terminals

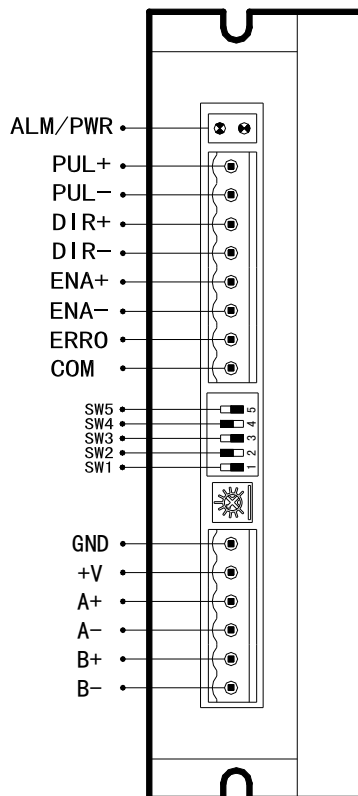

3-1. Control signal terminals

3-1-1. Description of Control signals terminals

Signal	Function	Description
PUL+	Pulse control signals	Be available on the rising edge, motor moves a step at the rising edge of pulse turning from low- level to high-level.
PUL-		
DIR+	Direction control signals	The direction of motor rotating changed by the turning of pulse between low-level and high-level .Once the pulse status is changed, the direction correspondingly turns. The original direction depends on the wiring of motor, which means the phase connection.
DIR-		
ENA+	Enable/release signal	Used for motor release. The stepper will not be active when ENA+ terminal connects to 24V and ENA- connects to low-level, in this case, the driver cuts off current of all phases and in free status, and also the temperature decrease. Otherwise, detaching the terminal means the motor is enabled all the time.
ENA-		
ERRO	Malfunction signal output	The malfunction signal is transferred by the ERRO and COM terminal when over-voltage or under-voltage.
COM		

3-1-2. Sequential chart of control signal

In order to ensure the reliability of the system response, please take the following advices.

- The high-level signal is effective when voltage is 24V; the low-level signal is effective when in the range of 0V to 0.5V.
- The ENA (enable) signal should be turned to high-level 3s before DIR (direction) signal or more.
- Ensure the falling edge of the DIR (direction) signal built 5 μ s before PUL (pulse) signal or more.
- The width of pulse should be more than 1.2 μ s
- The duration of the low-level pulse should be more than 1.2 μ s

The sequential chart shows as below:

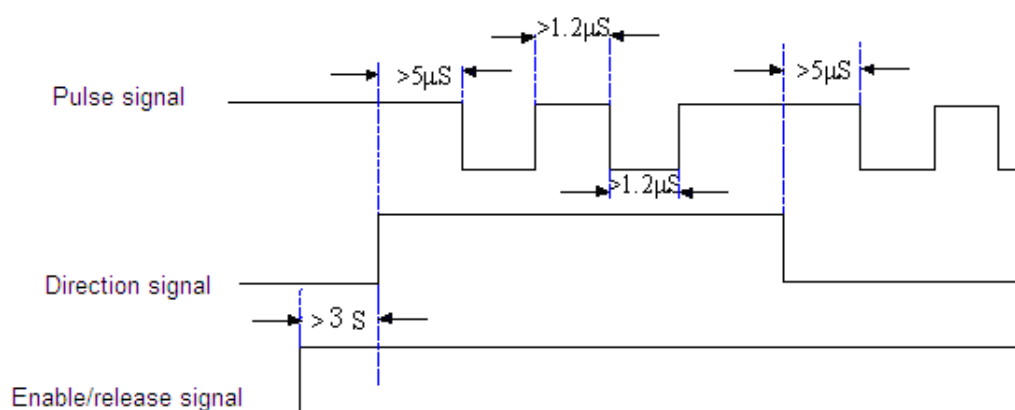

3-1-3. Input circuit

The connection on common anode way of the driver input circuit is shown as below:

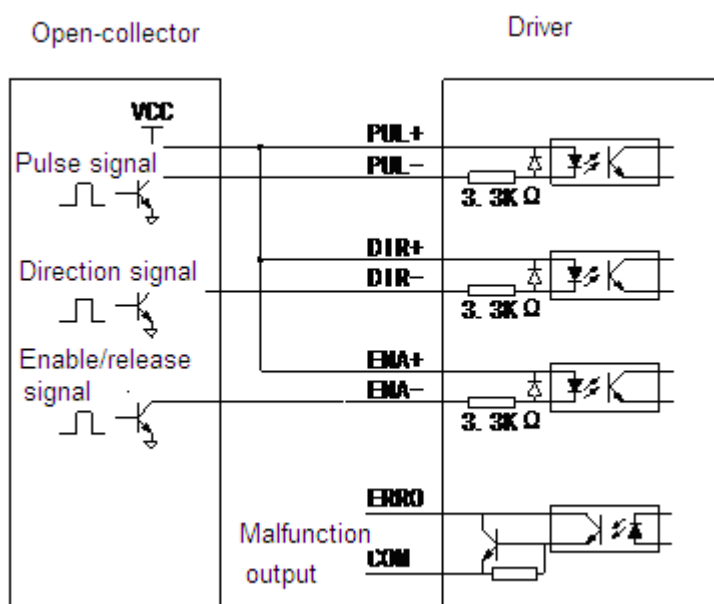

Note:

- The input signal should transfer by photoelectric isolation. Make sure the control

signal driven current is more than 8mA to keep the good conducting of the internal high-speed light-coupler.

- Light-coupler current limiting resistor is built in stepper driver. It is common to supply all the control signals with +24V.

3-2. Power Terminals

3-2-1. Description of Heavy-current terminal

Terminal	Function	Description
GND	DC ground terminal	DC ground terminal
+V	Anode terminal of DC	To be on the value between Min. voltage and maximal voltage
A+, A-	A-phase of motor	Direction of motor changed by the turning of A+ terminal and A-terminal.
B+, B-	B-phase of motor	Direction of motor changed by the turning of B+ terminal and B-terminal.

3-2-2. Requirement of power supply

- Don't connect the power supply terminal in reverse way.
- To keep the normal working of drive ,please ensure the power supply in this range: DP-504: 20~40VDC; DP-508: 20~80VDC
- It is advised to use non-regulated DC power supply, and make sure the current output of power is 60% higher than setting current on driver.
- Please ensure the current of power supply is higher than motor working current.

3-2-3. Wiring

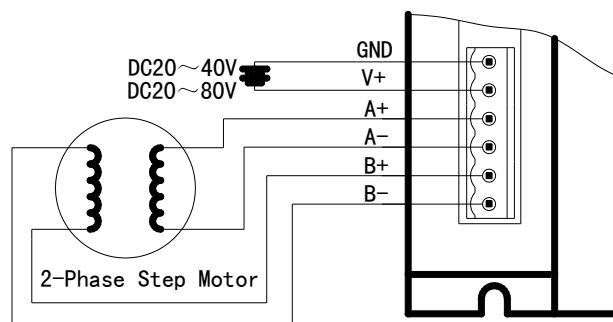

Note:

The motor performance depends on the connection between driver and motor. In most situation, the high-speed performance of motor is based on the power supply (the greater the power supply, the greater the high-speed torque, then avoid step missing), and the output moment is based on the setting current (the greater the setting current, the greater the output torque of motor).

However, please pay attention that the motor is getting heat when the value of power supply is larger, and the vibration is obviously when the motor at a low speed.

Above all, please do the connection according to the requirement all the time.

There are some typical connections for your reference as below:

- Parallel connection mode with 8-leads: the setting current value is 1.4 times than rated current on motor.
- Serial connection mode with 8-leads: the setting current value accounts for 50% of the rated current on motor.
- High-speed mode with 4/6 leads: the setting current value should be lower than the rated current on motor.
- High-torque mode with 6leads: the setting current value accounts for 70% of the rated current on motor.
-

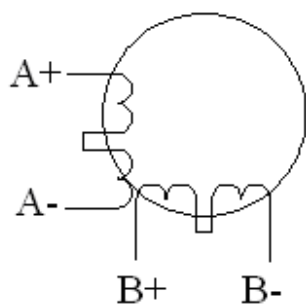

Serial-connection with 8-leads
large torque at a low speed

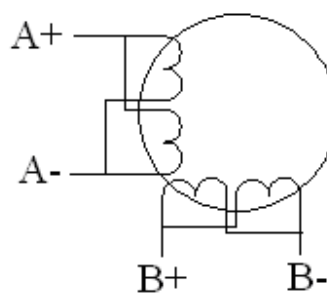

Parallel connection with 8-leads
good performance at a high speed

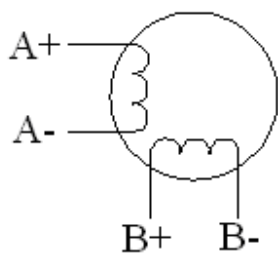

Motor with 4 leads

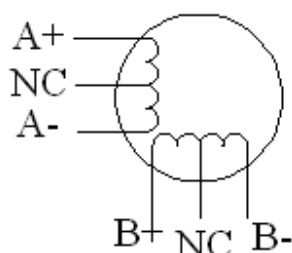

6-leads motor with large torque

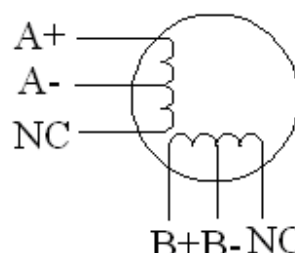

6-leads motor with high speed

3-3. Function Setting

The setting of the full-current/half-current and subdivision precision is based on the status of 5-bits switch. The details are shown as below:

SW1: Setting for half-current/full-current (SW1=OFF; half-current; SW1=ON; full-current)

SW2~SW5: Setting the precision of subdivision.

3-3-1. Current Setting

Set the current in the range of (0~5.0A) by single-turn potentiometers as below:

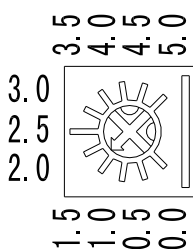

3-3-2. Subdivision Setting

The precision of the subdivision is based on the status of 4-bits switch, as below:

Subdivision multiple	Steps/turn (1.8°/step)	SW2	SW3	SW4	SW5
1	200	OFF	OFF	OFF	OFF
2	400	OFF	OFF	OFF	ON
4	800	OFF	OFF	ON	OFF
8	1600	OFF	OFF	ON	ON
16	3200	OFF	ON	OFF	OFF
32	6400	OFF	ON	OFF	ON
64	12800	OFF	ON	ON	OFF
128	25600	OFF	ON	ON	ON
5	1000	ON	OFF	OFF	OFF
10	2000	ON	OFF	OFF	ON
20	4000	ON	OFF	ON	OFF
25	5000	ON	OFF	ON	ON
40	8000	ON	ON	OFF	OFF
50	10000	ON	ON	OFF	ON
100	20000	ON	ON	ON	OFF
200	40000	ON	ON	ON	ON

3-4. Function for Protection

■ Indicator LED

Power indicator light: Green-light turning on means normal working.

Alarm indicator light: An alarm is raised when red-light turns on which means over-voltage or over-current; the red-light flashing at regular intervals means over-voltage alarm, the red-light turning on constantly means over-current alarm.

■ Malfunction output

The malfunction signal output transfers by the ERRO and COM terminal when there is over-voltage or under-voltage alarm.

■ Over-current/over-voltage protection

If the power voltage is more than up-limit value (DP-504: 50VDC, DP-508: 85VDC) or the current of motor is 20% higher than the setting value, the protection circuit will cut off the PWM output and the alarm indicator light turns on for user's reference.

Note: the drive stops working when the protection circuit is active. After you remove the malfunction and restart the driver, the driver working normally again.

4. Dimension installation and wiring

4-1. Dimension

reference: mm

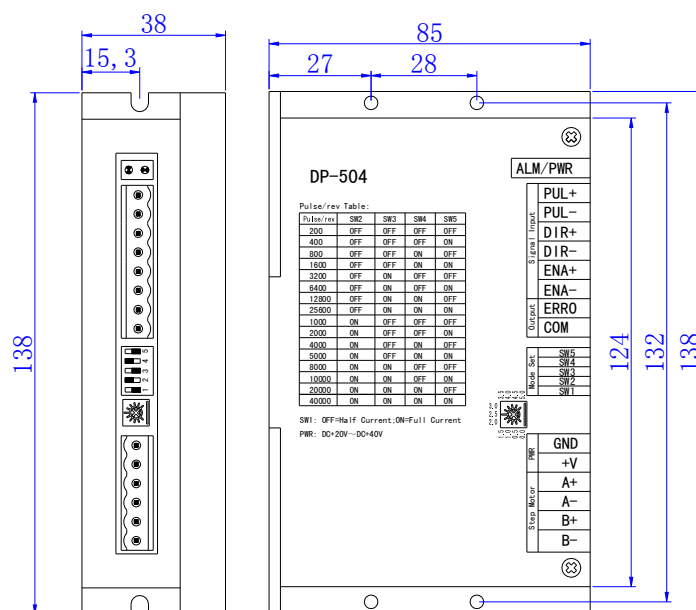

4-2. Installation

Install the driver in the well-ventilated cubicle under well protection and check the cooling fans periodically. Please leave at least 10cm around driver for cooling purpose. Avoid dust and moisture.

4-3. Typical Wiring

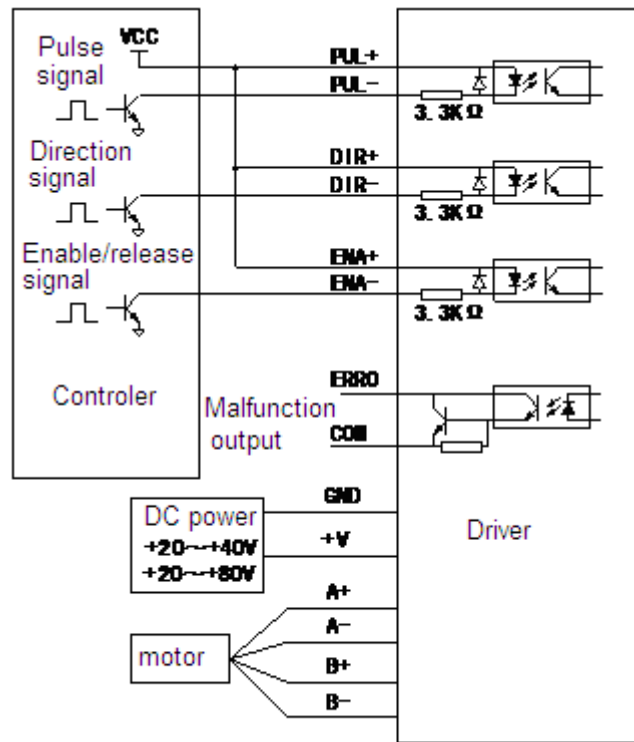

Note: please separate the power cables (power supply cable, phase cable) and the weak electricity cable in order to avoid interfering.

5. Malfunction Diagnoses and Solution

Malfunction	Causation	Solution
The power light doesn't work	Something wrong with the power supply	Check the power supply
	The voltage of power is not enough	Increase the voltage of power
The motor doesn't work	Current is too low	Reset the current
	Subdivision is too low	Reset the subdivision
	Protection circuit is active	Restart the driver
	The release signal is low	Remove this signal
	Power off	Restart the driver
	Connection on motor is incorrect	Check connection
	No pulse input	Adjust the pulse width and voltage
The direction of motor is incorrect	Inverse of phase-sequence	Exchange for phase-sequence
	Disconnection	Check connection
Alarm indicator turn on	Incorrect connection on motor	Rewire
	Over-voltage or too slow	Adjust the power voltage
	Motor or drive is damaged	Check the driver and motor
The torque of motor is too small	Acceleration is too high	Reduce the pulse acceleration
	Driver doesn't match with motor	Change a suitable driver

6. Motor Selection

The DP-504/DP-508 series driver is designed to match with two-phase hybrid stepper motor. Please select the suitable motor and driver.

Please pay attention to the torque and rated current when choosing a motor. The torque of motor is based on the dimension, the bigger the dimension, the greater the torque. And the current is based on the inductance, the smaller the inductance, the greater the current, and also leading to the perfect performance of motor at a high speed.

But when the motor is used with some special connections, the greater the current, the greater the torque, also the motor is getting hot. And the higher the power supply voltage, the greater the high-speed torque. And please note that the torque is greater when the motor runs at a higher speed.

